



2.7V to 3.6V and 4.5V to 5.5V, Low-Power, 4-/12-Channel, 2-Wire Serial, 12-Bit ADCs

MAX1236-MAX1239

General Description

The MAX1236–MAX1239 low-power, 12-bit, multichannel, analog-to-digital converters (ADCs) feature internal track/hold (T/H), voltage reference, clock, and an I²C™-compatible 2-wire serial interface. These devices operate from a single supply of 2.7V to 3.6V (MAX1237/MAX1239) or 4.5V to 5.5V (MAX1236/MAX1238) and require only 670μA at the maximum sampling rates of 94.4ksps. Supply current falls below 230μA for sampling rates under 46ksps. Auto-Shutdown™ powers down the devices between conversions reducing supply current to less than 1μA at low throughput rates. The MAX1236/MAX1237 have four analog input channels each, while the MAX1238/MAX1239 have twelve analog input channels each. The fully differential analog inputs are software configurable for unipolar or bipolar, and single-ended or differential operation.

The full-scale analog input range is determined by the internal reference or by an externally applied reference voltage ranging from 1V to V_{DD}. The MAX1237/MAX1239 feature a 2.048V internal reference and the MAX1236/MAX1238 feature a 4.096V internal reference.

The MAX1236/MAX1237 are available in an 8-pin μMAX package. The MAX1238/MAX1239 are available in a 16-pin QSOP package. The MAX1236–MAX1239 are guaranteed over the extended temperature range (-40°C to +85°C). For pin-compatible 10-bit parts, refer to the MAX1136–MAX1139 data sheet. For pin-compatible 8-bit parts, refer to the MAX1036–MAX1039 data sheet.

Applications

Hand-Held Portable Applications
 Medical Instruments
 Battery-Powered Test Equipment
 Solar-Powered Remote Systems
 Receive Signal Strength Indicators
 System Supervision

*AutoShutdown is a trademark of Maxim Integrated Products.
 I²C is a trademark of Philips Corp.*

Features

- ◆ High-Speed I²C-Compatible Serial Interface
 - 400kHz Fast Mode
 - 1.7MHz High-Speed Mode
- ◆ Single-Supply
 - 2.7V to 3.6V (MAX1237/MAX1239)
 - 4.5V to 5.5V (MAX1236/MAX1238)
- ◆ Internal Reference
 - 2.048V (MAX1237/MAX1239)
 - 4.096V (MAX1236/MAX1238)
- ◆ External Reference: 1V to V_{DD}
- ◆ Internal Clock
- ◆ 4-Channel Single-Ended or 2-Channel Fully Differential (MAX1236/MAX1237)
- ◆ 12-Channel Single-Ended or 6-Channel Fully Differential (MAX1238/MAX1239)
- ◆ Internal FIFO with Channel-Scan Mode
- ◆ Low Power
 - 670μA at 94.4ksps
 - 230μA at 40ksps
 - 60μA at 10ksps
 - 6μA at 1ksps
 - 0.5μA in Power-Down Mode
- ◆ Software-Configurable Unipolar/Bipolar
- ◆ Small Packages
 - 8-Pin μMAX (MAX1236/MAX1237)
 - 16-Pin QSOP (MAX1238/MAX1239)

Ordering Information

PART	TEMP RANGE	PIN-PACKAGE	INL (LSB)
MAX1236EUA*	-40°C to +85°C	8 μMAX	±1
MAX1237EUA*	-40°C to +85°C	8 μMAX	±1
MAX1238EEE	-40°C to +85°C	16 QSOP	±1
MAX1239EEE	-40°C to +85°C	16 QSOP	±1

*Future Product—contact factory for availability

*Pin Configurations appear at end of data sheet.
 Typical Operating Circuit appears at end of data sheet.
 Selector Guide appears at end of data sheet.*



2.7V to 3.6V and 4.5V to 5.5V, Low-Power, 4-/12-Channel, 2-Wire Serial, 12-Bit ADCs

ABSOLUTE MAXIMUM RATINGS

V_{DD} to GND-0.3V to +6V
 AIN0–AIN11,
 REF to GND-0.3V to the lower of (V_{DD} + 0.3V) and 6V
 SDA, SCL to GND-0.3V to +6V
 Maximum Current Into Any Pin±50mA
 Continuous Power Dissipation (T_A = +70°C)
 8-Pin μ MAX (derate 4.5mW/°C above +70°C)362mW
 16-Pin QSOP (derate 8.3mW/°C above +70°C)666.7mW

Operating Temperature Range-40°C to +85°C
 Junction Temperature+150°C
 Storage Temperature Range-60°C to +150°C
 Lead Temperature (soldering, 10s)+300°C

Stresses beyond those listed under "Absolute Maximum Ratings" may cause permanent damage to the device. These are stress ratings only, and functional operation of the device at these or any other conditions beyond those indicated in the operational sections of the specifications is not implied. Exposure to absolute maximum rating conditions for extended periods may affect device reliability.

ELECTRICAL CHARACTERISTICS

(V_{DD} = 2.7V to 3.6V (MAX1237/MAX1239), V_{DD} = 4.5V to 5.5V (MAX1236/MAX1238), V_{REF} = 2.048V (MAX1237/MAX1239), V_{REF} = 4.096V (MAX1236/MAX1238), C_{REF} = 0.1 μ F, f_{SCL} = 1.7MHz, T_A = T_{MIN} to T_{MAX}, unless otherwise noted. Typical values are at T_A = +25°C, see Tables 1–5 for programming notation.)

PARAMETER	SYMBOL	CONDITIONS	MIN	TYP	MAX	UNITS
DC ACCURACY (NOTE 1)						
Resolution			12			Bits
Relative Accuracy (Note 2)	INL				±1	LSB
Differential Nonlinearity	DNL	No missing codes over temperature			±1	LSB
Offset Error					±4	LSB
Offset-Error Temperature Coefficient		Relative to FSR		0.3		ppm/°C
Gain Error (Note 3)					±4	LSB
Gain-Temperature Coefficient		Relative to FSR		0.3		ppm/°C
Channel-to-Channel Offset Matching				±0.1		LSB
Channel-to-Channel Gain Matching				±0.1		LSB
DYNAMIC PERFORMANCE (f_{IN(SINE-WAVE)} = 10kHz, V_{IN(P-P)} = V_{REF}, f_{SAMPLE} = 94.4ksps)						
Signal-to-Noise Plus Distortion	SINAD			70		dB
Total Harmonic Distortion	THD	Up to the 5th harmonic		-78		dB
Spurious-Free Dynamic Range	SFDR			78		dB
Full-Power Bandwidth		SINAD > 68dB		3		MHz
Full-Linear Bandwidth		-3dB point		5		MHz
CONVERSION RATE						
Conversion Time (Note 5)	t _{CONV}	Internal clock		7.5		μ s
		External clock	10.6			

2.7V to 3.6V and 4.5V to 5.5V, Low-Power, 4-/12-Channel, 2-Wire Serial, 12-Bit ADCs

MAX1236-MAX1239

ELECTRICAL CHARACTERISTICS (continued)

($V_{DD} = 2.7V$ to $3.6V$ (MAX1237/MAX1239), $V_{DD} = 4.5V$ to $5.5V$ (MAX1236/MAX1238), $V_{REF} = 2.048V$ (MAX1237/MAX1239), $V_{REF} = 4.096V$ (MAX1236/MAX1238), $C_{REF} = 0.1\mu F$, $f_{SCL} = 1.7MHz$, $T_A = T_{MIN}$ to T_{MAX} , unless otherwise noted. Typical values are at $T_A = +25^\circ C$, see Tables 1–5 for programming notation.)

PARAMETER	SYMBOL	CONDITIONS	MIN	TYP	MAX	UNITS	
Throughput Rate	f_{SAMPLE}	Internal clock, SCAN[1:0] = 01		51		ksps	
		Internal clock, SCAN[1:0] = 00 CS[3:0] = 1011 (MAX1238/MAX1239)		51			
		External clock		94.4			
Track/Hold Acquisition Time			800			ns	
Internal Clock Frequency				2.8		MHz	
Aperture Delay (Note 6)	t_{AD}	External clock, fast mode		60		ns	
		External clock, high-speed mode		30			
ANALOG INPUT (AIN0–AIN11)							
Input-Voltage Range, Single-Ended and Differential (Note 7)		Unipolar	0		V_{REF}	V	
		Bipolar	0		$\pm V_{REF}/2$		
Input Multiplexer Leakage Current		ON/OFF leakage current, $V_{AIN-} = 0$ or V_{DD}		± 0.01	± 1	μA	
Input Capacitance	C_{IN}			22		pF	
INTERNAL REFERENCE (NOTE 8)							
Reference Voltage	V_{REF}	$T_A = +25^\circ C$	MAX1237/MAX1239	1.968	2.048	2.128	V
			MAX1236/MAX1238	3.936	4.096	4.256	
Reference-Voltage Temperature Coefficient	TCV_{REF}			25		ppm/ $^\circ C$	
REF Short-Circuit Current					2	mA	
REF Source Impedance				1.5		k Ω	
EXTERNAL REFERENCE							
REF Input-Voltage Range (Note 9)	V_{REF}		1		V_{DD}	V	
REF Input Current	I_{REF}	$f_{SAMPLE} = 94.4ksps$			40	μA	
DIGITAL INPUTS/OUTPUTS (SCL, SDA)							
Input-High Voltage	V_{IH}		$0.7 \times V_{DD}$			V	
Input-Low Voltage	V_{IL}			$0.3 \times V_{DD}$		V	
Input Hysteresis	V_{HYST}		$0.1 \times V_{DD}$			V	
Input Current	I_{IN}	$V_{IN} = 0$ to V_{DD}			± 10	μA	
Input Capacitance	C_{IN}			15		pF	
Output Low Voltage	V_{OL}	$I_{SINK} = 3mA$			0.4	V	

2.7V to 3.6V and 4.5V to 5.5V, Low-Power, 4-/12-Channel, 2-Wire Serial, 12-Bit ADCs

ELECTRICAL CHARACTERISTICS (continued)

($V_{DD} = 2.7V$ to $3.6V$ (MAX1237/MAX1239), $V_{DD} = 4.5V$ to $5.5V$ (MAX1236/MAX1238), $V_{REF} = 2.048V$ (MAX1237/MAX1239), $V_{REF} = 4.096V$ (MAX1236/MAX1238), $C_{REF} = 0.1\mu F$, $f_{SCL} = 1.7MHz$, $T_A = T_{MIN}$ to T_{MAX} , unless otherwise noted. Typical values are at $T_A = +25^\circ C$, see Tables 1–5 for programming notation.)

PARAMETER	SYMBOL	CONDITIONS	MIN	TYP	MAX	UNITS
POWER REQUIREMENTS						
Supply Voltage	V_{DD}	MAX1237/MAX1239	2.7		5.5	V
		MAX1236/MAX1238	4.5		5.5	
Supply Current	I_{DD}	$f_{SAMPLE} = 94.4ksps$ external clock	Internal reference	900	1150	μA
			External reference	670	900	
		$f_{SAMPLE} = 40ksps$ internal clock	Internal reference	530		
			External reference	230		
		$f_{SAMPLE} = 10ksps$ internal clock	Internal reference	380		
			External reference	60		
		$f_{SAMPLE} = 1ksps$ internal clock	Internal reference	330		
			External reference	6		
Shutdown (internal REF off)			0.5	10		
Power-Supply Rejection Ratio (Note 11)	PSRR	Full-scale input		± 0.5	± 0.2	LSB/V

TIMING CHARACTERISTICS (Figure 1)

($V_{DD} = 2.7V$ to $3.6V$ (MAX1237/MAX1239), $V_{DD} = 4.5V$ to $5.5V$ (MAX1236/MAX1238), $V_{REF} = 2.048V$ (MAX1237/MAX1239), $V_{REF} = 4.096V$ (MAX1236/MAX1238), $C_{REF} = 0.1\mu F$, $f_{SCL} = 1.7MHz$, $T_A = T_{MIN}$ to T_{MAX} , unless otherwise noted. Typical values are at $T_A = +25^\circ C$, see Tables 1–5 for programming notation.)

PARAMETER	SYMBOL	CONDITIONS	MIN	TYP	MAX	UNITS
TIMING CHARACTERISTICS for FAST MODE						
Serial-Clock Frequency	f_{SCL}				400	kHz
Bus Free Time Between a STOP (P) and a START (S) Condition	t_{BUF}		1.3			μs
Hold Time for START (S) Condition	$t_{HD, STA}$		0.6			μs
Low Period of the SCL Clock	t_{LOW}		1.3			μs
High Period of the SCL Clock	t_{HIGH}		0.6			μs
Setup Time for a Repeated START Condition (Sr)	$t_{SU, STA}$		0.6			μs
Data Hold Time (Note 12)	$t_{HD, DAT}$		0		900	ns
Data Setup Time	$t_{SU, DAT}$		100			ns
Rise Time of Both SDA and SCL Signals, Receiving	t_R	Measured from $0.3V_{DD} - 0.7V_{DD}$	$20 + 0.1C_B$		300	ns
Fall Time of SDA Transmitting	t_F	Measured from $0.3V_{DD} - 0.7V_{DD}$	$20 + 0.1C_B$		300	ns
Setup Time for STOP (P) Condition	$t_{SU, STO}$		0.6			μs
Capacitive Load for Each Bus Line	C_B				400	pF
Pulse Width of Spike Suppressed	t_{SP}				50	ns

2.7V to 3.6V and 4.5V to 5.5V, Low-Power, 4-/12-Channel, 2-Wire Serial, 12-Bit ADCs

MAX1236-MAX1239

TIMING CHARACTERISTICS (Figure 1) (continued)

(V_{DD} = 2.7V to 3.6V (MAX1237/MAX1239), V_{DD} = 4.5V to 5.5V (MAX1236/MAX1238), V_{REF} = 2.048V (MAX1237/MAX1239), V_{REF} = 4.096V (MAX1236/MAX1238), C_{REF} = 0.1μF, f_{SCL} = 1.7MHz, T_A = T_{MIN} to T_{MAX}, unless otherwise noted. Typical values are at T_A = +25°C, see Tables 1–5 for programming notation.)

PARAMETER	SYMBOL	CONDITIONS	MIN	TYP	MAX	UNITS
TIMING CHARACTERISTICS for HIGH-SPEED MODE (C_B = 400pF, Note 13)						
Serial Clock Frequency	f _{SCLH}	(Note 14)			1.7	MHz
Hold Time, Repeated START Condition (Sr)	t _{HD, STA}		160			ns
Low Period of the SCL Clock	t _{LOW}		320			ns
High Period of the SCL Clock	t _{HIGH}		120			ns
Setup Time for a Repeated START Condition (Sr)	t _{SU, STA}		160			ns
Data Hold Time (Note 12)	t _{HD, DAT}		0		150	ns
Data Setup Time	t _{SU, DAT}		10			ns
Rise Time of SCL Signal (Current Source Enabled)	t _{RCL}		20		80	ns
Rise Time of SCL Signal after Acknowledge Bit	t _{RCL1}	Measured from 0.3V _{DD} - 0.7V _{DD}	20		160	ns
Fall Time of SCL Signal	t _{FCL}	Measured from 0.3V _{DD} - 0.7V _{DD}	20		80	ns
Rise Time of SDA Signal	t _{RDA}	Measured from 0.3V _{DD} - 0.7V _{DD}	20		160	ns
Fall Time of SDA Signal	t _{FDA}	Measured from 0.3V _{DD} - 0.7V _{DD}	20		160	ns
Setup Time for STOP (P) Condition	t _{SU, STO}		160			ns
Capacitive Load for Each Bus Line	C _B				400	pF
Pulse Width of Spike Suppressed (Notes 12 and 14)	t _{SP}		0		10	ns

Note 1: For DC accuracy, the MAX1236/MAX1238 are tested at V_{DD} = 5V and the MAX1237/MAX1239 are tested at V_{DD} = 3V. All devices are configured for unipolar, single-ended inputs.

Note 2: Relative accuracy is the deviation of the analog value at any code from its theoretical value after the full-scale range and offsets have been calibrated.

Note 3: Offset nulled.

Note 4: Ground ON channel; sine-wave applied to all OFF channels.

Note 5: Conversion time is defined as the number of clock cycles needed for conversion multiplied by the clock period. Conversion time does not include acquisition time. SCL is the conversion clock in the external clock mode.

Note 6: A filter on the SDA and SCL inputs suppresses noise spikes and delays the sampling instant.

Note 7: The absolute input-voltage range for the analog inputs (AIN0–AIN11) is from GND to V_{DD}.

Note 8: When the internal reference is configured to be available at AIN_J/REF (SEL[2:1] = 11) decouple AIN_J/REF to GND with a 0.01μF capacitor.

Note 9: ADC performance is limited by the converter's noise floor, typically 300μV_{p-p}.

Note 10: Not production tested. Guaranteed by design.

Note 11: Measured as $\frac{|V_{FS}(3.6V) - V_{FS}(2.7V)|}{(3.6V - 2.7V)}$ for the MAX1237/MAX1239 and $\frac{|V_{FS}(5.5V) - V_{FS}(4.5V)|}{(5.5V - 4.5V)}$ for the MAX1236/MAX1238.

Note 12: A master device must provide a data hold time for SDA (referred to V_{IL} of SCL) in order to bridge the undefined region of SCL's falling edge (see Figure 1).

Note 13: C_B = total capacitance of one bus line in pF.

Note 14: f_{SCL} must meet the minimum clock low time plus the rise/fall times.

2.7V to 3.6V and 4.5V to 5.5V, Low-Power, 4-/12-Channel, 2-Wire Serial, 12-Bit ADCs

Typical Operating Characteristics

($V_{DD} = 3.3V$ (MAX1237/MAX1239), $V_{DD} = 5V$ (MAX1236/MAX1238), $f_{SCL} = 1.7MHz$, (50% duty cycle), $f_{SAMPLE} = 94.4ksps$, single-ended, unipolar, $T_A = +25^{\circ}C$, unless otherwise noted.)

DIFFERENTIAL NONLINEARITY vs. DIGITAL CODE

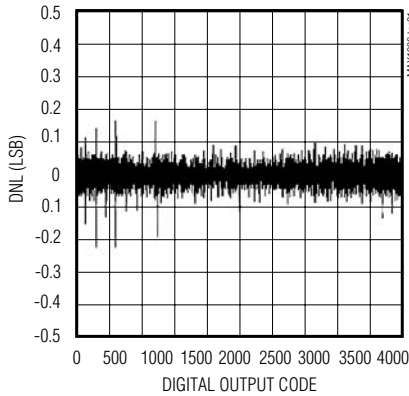

INTEGRAL NONLINEARITY vs. DIGITAL CODE

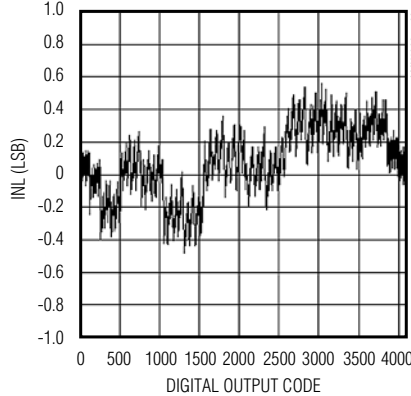

FFT PLOT

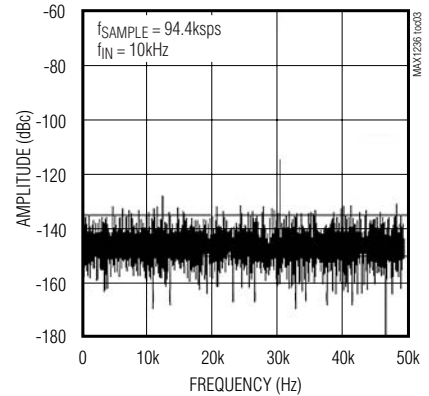

SUPPLY CURRENT vs. TEMPERATURE (MAX1238/MAX1239)

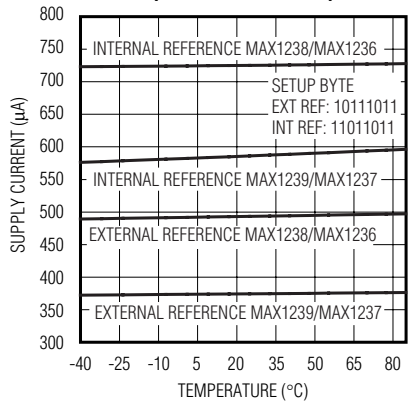

SHUTDOWN SUPPLY CURRENT vs. SUPPLY VOLTAGE

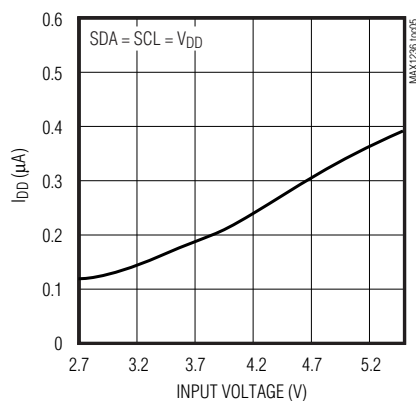

SHUTDOWN SUPPLY CURRENT vs. TEMPERATURE

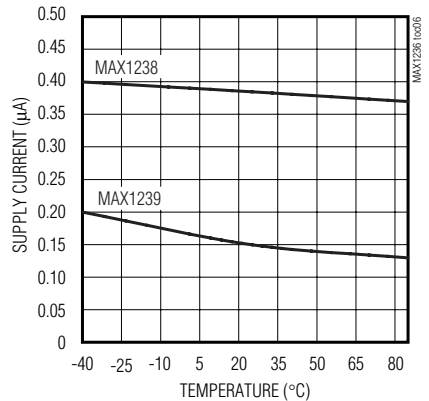

AVERAGE SUPPLY CURRENT vs. CONVERSION RATE (EXTERNAL CLOCK)

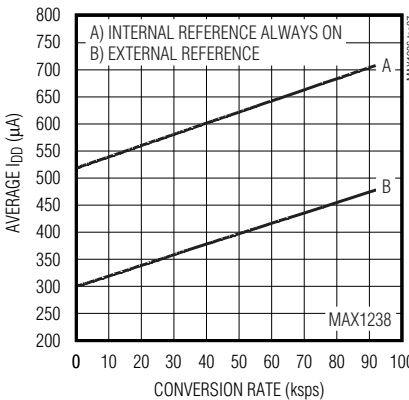

INTERNAL REFERENCE VOLTAGE vs. TEMPERATURE

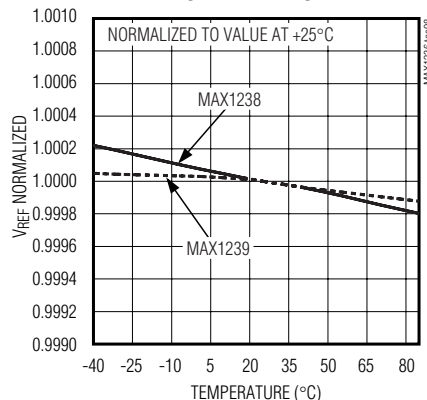

NORMALIZED REFERENCE VOLTAGE vs. SUPPLY VOLTAGE

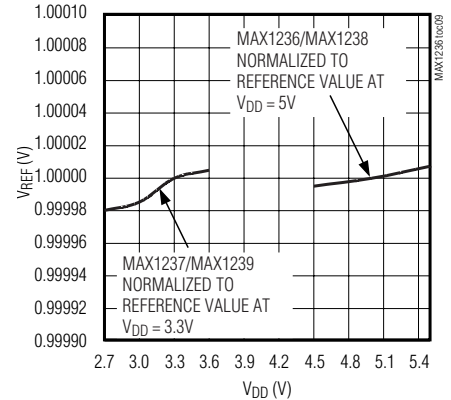

2.7V to 3.6V and 4.5V to 5.5V, Low-Power, 4-/12-Channel, 2-Wire Serial, 12-Bit ADCs

Typical Operating Characteristics (continued)

($V_{DD} = 3.3V$ (MAX1237/MAX1239), $V_{DD} = 5V$ (MAX1236/MAX1238), $f_{SCL} = 1.7MHz$, (50% duty cycle), $f_{SAMPLE} = 94.4ksp/s$, single-ended, unipolar, $T_A = +25^{\circ}C$, unless otherwise noted.)

MAX1236-MAX1239

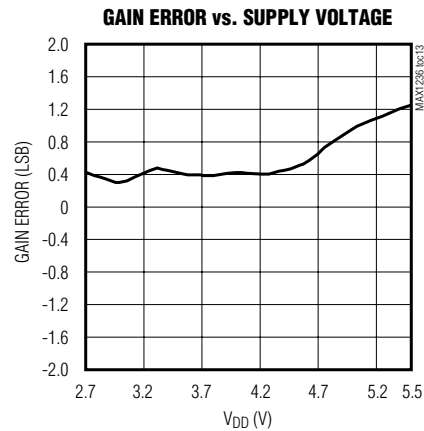
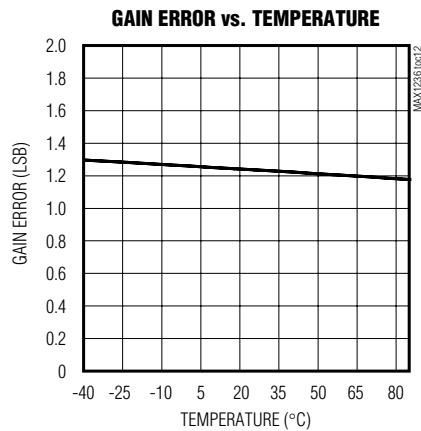
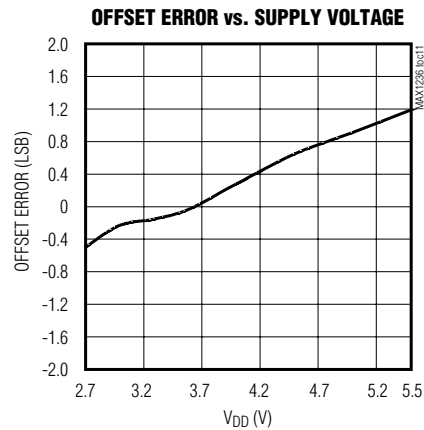
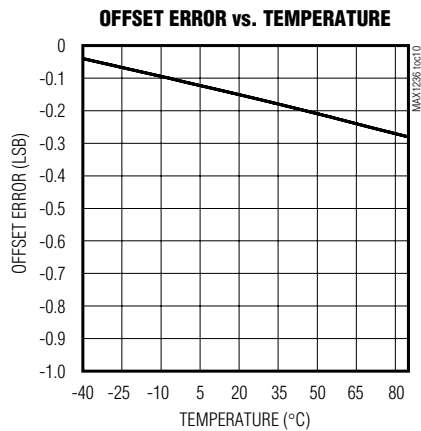

2.7V to 3.6V and 4.5V to 5.5V, Low-Power, 4-/12-Channel, 2-Wire Serial, 12-Bit ADCs

Pin Description

PIN		NAME	DESCRIPTION
MAX1236 MAX1237	MAX1238 MAX1239		
1, 2, 3	1, 2, 3	AIN0–AIN2	Analog Inputs
—	4–8	AIN3–AIN7	
—	16, 15, 14	AIN8–AIN10	
4	—	AIN3/REF	Analog Input 3/Reference Input or Output. Selected in the Setup Register (see Tables 1 and 6).
—	13	AIN11/REF	Analog Input 11/Reference Input or Output. Selected in the Setup Register (see Tables 1 and 6).
5	9	SCL	Clock Input
6	10	SDA	Data Input/Output
7	11	GND	Ground
8	12	V _{DD}	Positive Supply. Bypass to GND with a 0.1μF capacitor.

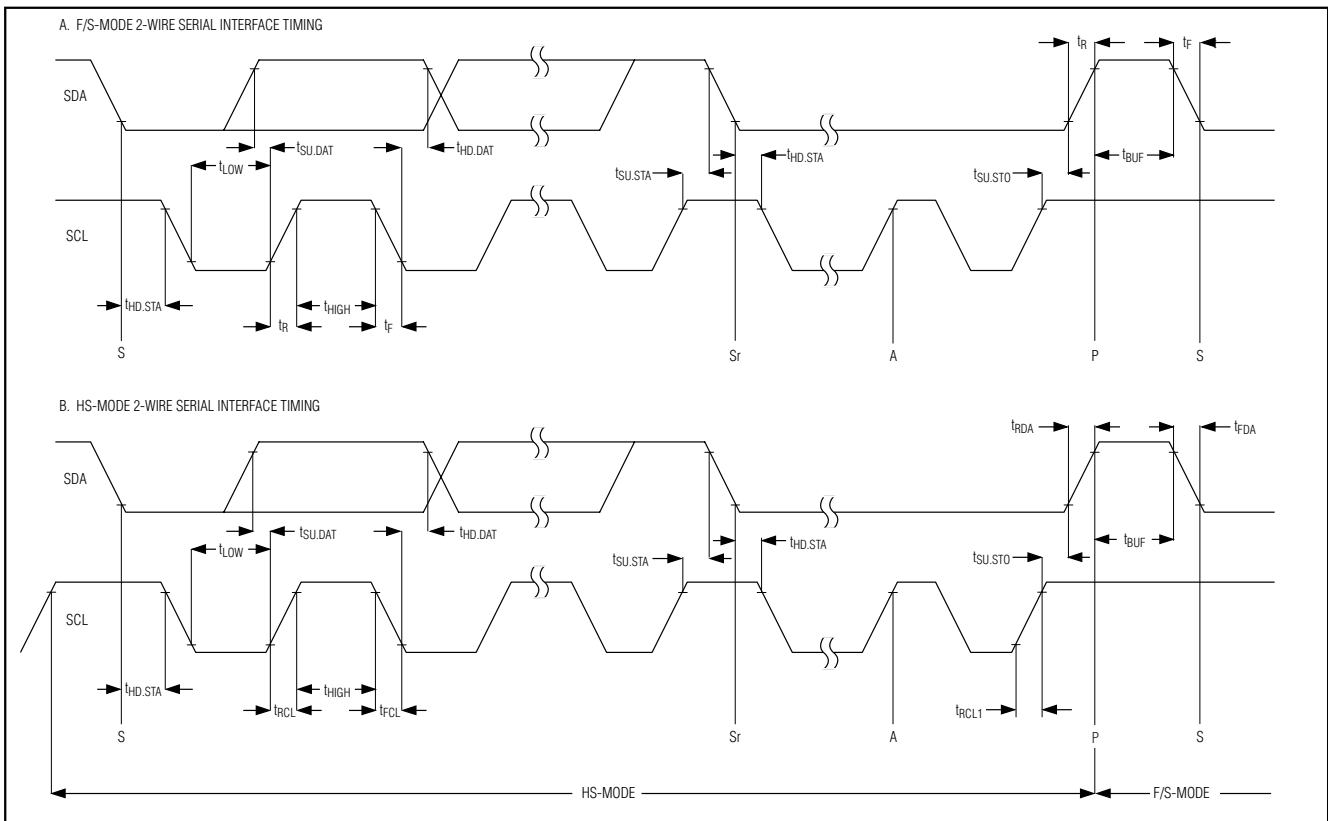

Figure 1. 2-Wire Serial Interface Timing

2.7V to 3.6V and 4.5V to 5.5V, Low-Power, 4-/12-Channel, 2-Wire Serial, 12-Bit ADCs

MAX1236-MAX1239

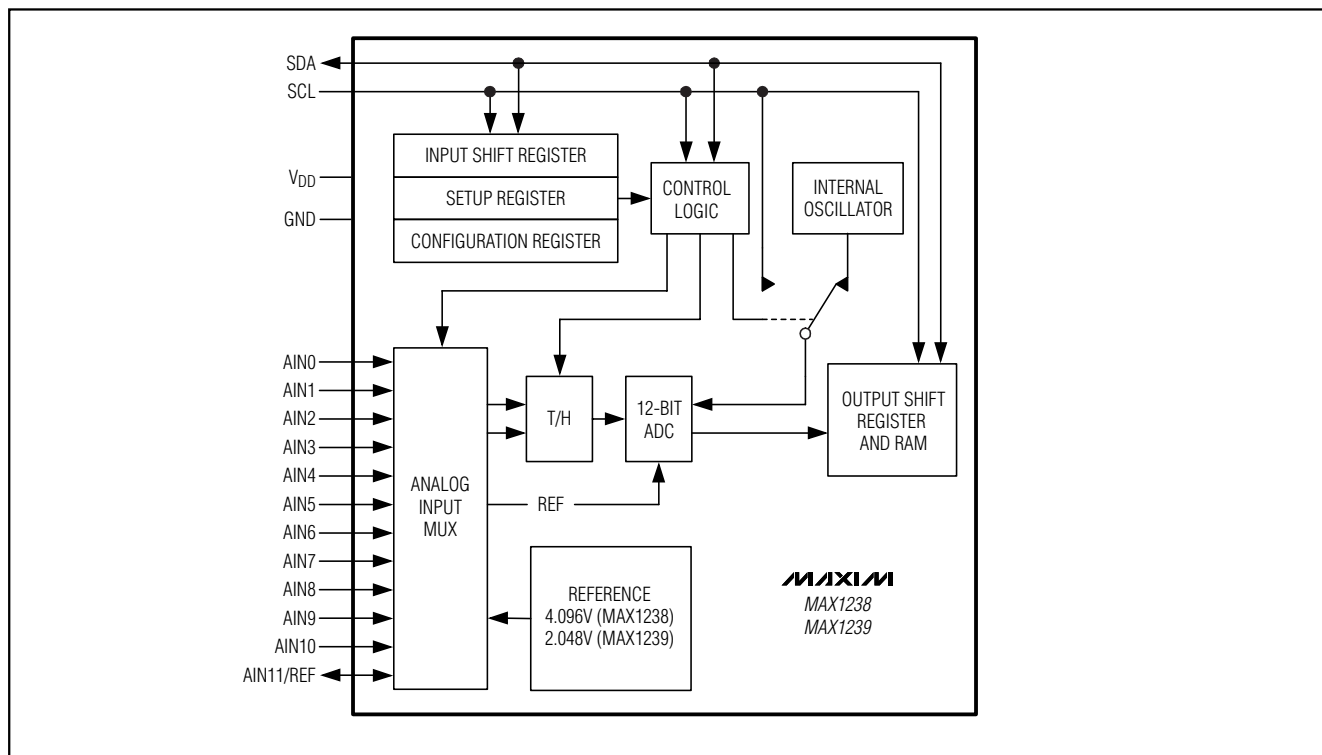

Figure 2. MAX1238/MAX1239 Simplified Functional Diagram

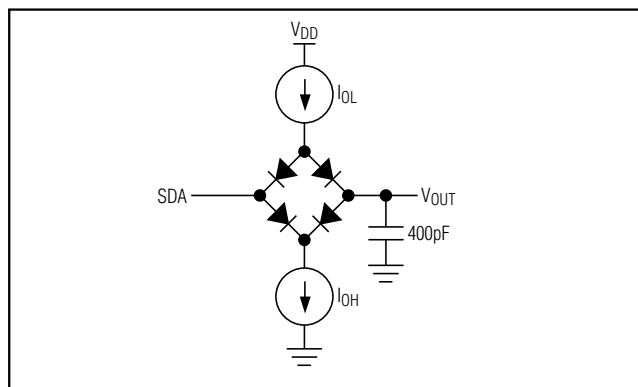

Figure 3. Load Circuit

Detailed Description

The MAX1236–MAX1239 analog-to-digital converters (ADCs) use successive-approximation conversion techniques and fully differential input track/hold (T/H) circuitry to capture and convert an analog signal to a serial 12-bit digital output. The MAX1236/MAX1237 are 4-channel ADCs, and the MAX1238/MAX1239 are 12-channel ADCs. These devices feature a high-speed 2-wire serial interface supporting data rates up to 1.7MHz.

Figure 2 shows the simplified internal structure for the MAX1238/MAX1239.

Power Supply

The MAX1236–MAX1239 operates from a single supply and consumes 670 μ A (typ) at sampling rates up to 94.4ksp/s. The MAX1237/MAX1239 feature a 2.048V internal reference and the MAX1236/MAX1238 feature a 4.096V internal reference. All devices can be configured for use with an external reference from 1V to V_{DD}.

Analog Input and Track/Hold

The MAX1236–MAX1239 analog-input architecture contains an analog-input multiplexer (mux), a fully differential track-and-hold (T/H) capacitor, T/H switches, a comparator, and a fully differential switched capacitive digital-to-analog converter (DAC) (Figure 4).

In single-ended mode the analog input multiplexer connects C_{T/H} between the analog input selected by CS[3:0] (see the *Configuration Setup Bytes* section) and GND (Table 3). In differential mode, the analog-input multiplexer connects C_{T/H} to the “+” and “-” analog inputs selected by CS[3:0] (Table 4).

During the acquisition interval the T/H switches are in the track position and C_{T/H} charges to the analog input

2.7V to 3.6V and 4.5V to 5.5V, Low-Power, 4-/12-Channel, 2-Wire Serial, 12-Bit ADCs

signal. At the end of the acquisition interval, the T/H switches move to the hold position retaining the charge on $C_{T/H}$ as a stable sample of the input signal.

During the conversion interval, the switched capacitive DAC adjusts to restore the comparator input voltage to 0V within the limits of a 12-bit resolution. This action requires 12 conversion clock cycles and is equivalent to transferring a charge of $11\text{pF} \times (V_{IN+} - V_{IN-})$ from $C_{T/H}$ to the binary weighted capacitive DAC, forming a digital representation of the analog input signal.

Sufficiently low source impedance is required to ensure an accurate sample. A source impedance of up to $1.5\text{k}\Omega$ does not significantly degrade sampling accuracy. To minimize sampling errors with higher source impedances, connect a 100pF capacitor from the analog input to GND. This input capacitor forms an RC filter with the source impedance limiting the analog-input bandwidth. For larger source impedances, use a buffer amplifier to maintain analog-input signal integrity and bandwidth.

When operating in internal clock mode, the T/H circuitry enters its tracking mode on the eighth rising clock edge of the address byte, see the *Slave Address* section. The T/H circuitry enters hold mode on the falling clock edge of the acknowledge bit of the address byte (the ninth clock pulse). A conversion, or series of conversions, are then internally clocked and the MAX1236–MAX1239 holds SCL low. With external clock mode, the T/H circuitry enters track mode after a valid address on the rising edge of the clock during the read ($R/\bar{W} = 1$) bit. Hold mode is then entered on the rising edge of the second

clock pulse during the shifting out of the first byte of the result. The conversion is performed during the next 12 clock cycles.

The time required for the T/H circuitry to acquire an input signal is a function of the input sample capacitance. If the analog-input source impedance is high, the acquisition time constant lengthens and more time must be allowed between conversions. The acquisition time (t_{ACQ}) is the minimum time needed for the signal to be acquired. It is calculated by:

$$t_{ACQ} \geq 9 \times (R_{SOURCE} + R_{IN}) \times C_{IN}$$

where R_{SOURCE} is the analog-input source impedance, $R_{IN} = 2.5\text{k}\Omega$, and $C_{IN} = 22\text{pF}$. t_{ACQ} is $1.5/f_{SCL}$ for internal clock mode and $t_{ACQ} = 2/f_{SCL}$ for external clock mode.

Analog Input Bandwidth

The MAX1236–MAX1239 feature input-tracking circuitry with a 5MHz small-signal bandwidth. The 5MHz input bandwidth makes it possible to digitize high-speed transient events and measure periodic signals with bandwidths exceeding the ADC's sampling rate by using under sampling techniques. To avoid high-frequency signals being aliased into the frequency band of interest, anti-alias filtering is recommended.

Analog Input Range and Protection

Internal protection diodes clamp the analog input to V_{DD} and GND. These diodes allow the analog inputs to

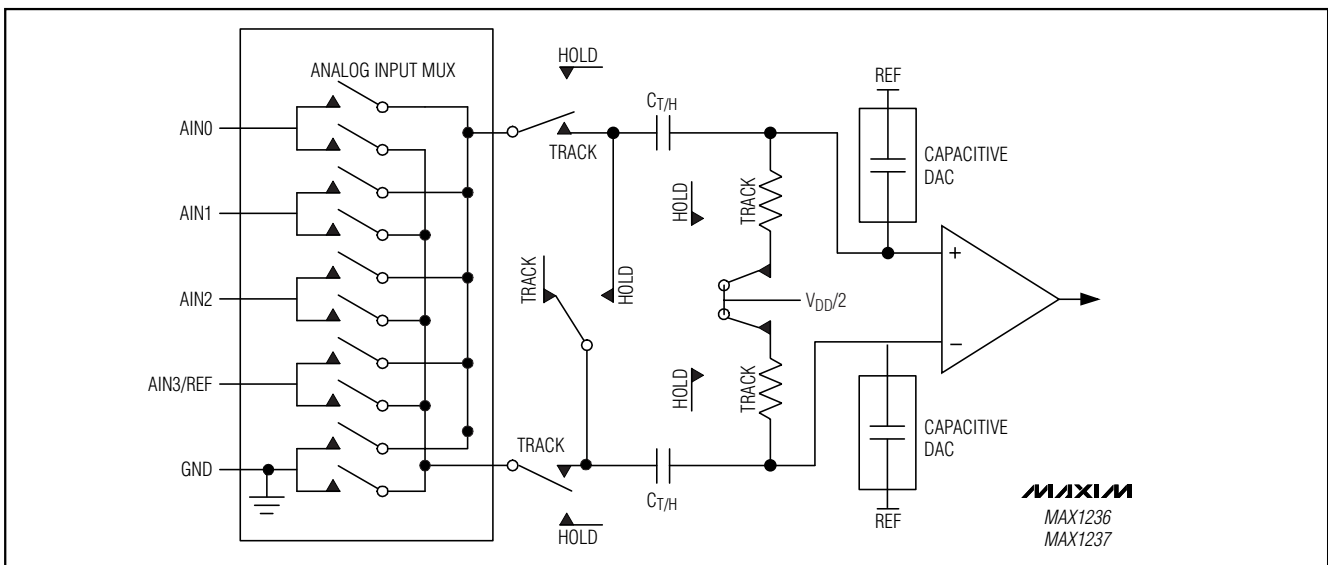

Figure 4. Equivalent Input Circuit

2.7V to 3.6V and 4.5V to 5.5V, Low-Power, 4-/12-Channel, 2-Wire Serial, 12-Bit ADCs

swing from (GND - 0.3V) to (V_{DD} + 0.3V) without causing damage to the device. For accurate conversions, the inputs must not go more than 50mV below GND or above V_{DD}.

Single-Ended/Differential Input

The SGL/DIF of the configuration byte configures the MAX1236-MAX1239 analog-input circuitry for single-ended or differential inputs (Table 2). In single-ended mode (SGL/DIF = 1), the digital conversion results are the difference between the analog input selected by CS[3:0] and GND (Table 3). In differential mode (SGL/DIF = 0) the digital conversion results are the difference between the "+" and the "-" analog inputs selected by CS[3:0] (Table 4).

Unipolar/Bipolar

When operating in differential mode, the BIP/UNI bit of the set-up byte (Table 1) selects unipolar or bipolar operation. Unipolar mode sets the differential input range from 0 to V_{REF}. A negative differential analog input in unipolar mode will cause the digital output code to be zero. Selecting bipolar mode sets the differential input range to $\pm V_{REF}/2$. The digital output code is binary in unipolar mode and two's complement in bipolar mode, see the *Transfer Functions* section.

In single-ended mode the MAX1236-MAX1239 will always operate in unipolar mode irrespective of BIP/UNI. The analog inputs are internally referenced to GND with a full-scale input range from 0 to V_{REF}.

2-Wire Digital Interface

The MAX1236-MAX1239 feature a 2-wire interface consisting of a serial data line (SDA) and serial clock line (SCL). SDA and SCL facilitate bidirectional communication between the MAX1236-MAX1239 and the master at rates up to 1.7MHz. The MAX1236-MAX1239 are slaves that transfer and receive data. The master (typically a microcontroller) initiates data transfer on the bus and generates the SCL signal to permit that transfer.

SDA and SCL must be pulled high. This is typically done with pullup resistors (750 Ω or greater), see the *Typical Operating Circuit*. Series resistors (R_s) are optional. They protect the input architecture of the MAX1236-MAX1239 from high voltage spikes on the bus lines, minimize crosstalk, and undershoot of the bus signals.

Bit Transfer

One data bit is transferred during each SCL clock cycle. A minimum of eighteen clock cycles are required to transfer the data in or out of the MAX1236-MAX1239. The data on SDA must remain stable during the high period of the SCL clock pulse. Changes in SDA while SCL is stable are considered control signals (see the

START and STOP Conditions section). Both SDA and SCL remain high when the bus is not busy.

START and STOP Conditions

The master initiates a transmission with a START condition (S), a high-to-low transition on SDA while SCL is high. The master terminates a transmission with a STOP condition (P), a low-to-high transition on SDA while SCL is high (Figure 5). A repeated START condition (Sr) can be used in place of a STOP condition to leave the bus active and the interface mode unchanged (see HS mode).

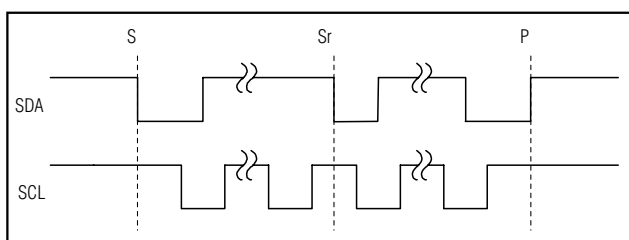

Figure 5. START and STOP Conditions

Acknowledge Bits

Data transfers are acknowledged with an acknowledge bit (A) or a not-acknowledge bit (A). Both the master and the MAX1236-MAX1239 (slave) generate acknowledge bits. To generate an acknowledge, the receiving device must pull SDA low before the rising edge of the acknowledge-related clock pulse (ninth pulse) and keep it low during the high period of the clock pulse (Figure 6). To generate a not-acknowledge, the receiver allows SDA to be pulled high before the rising edge of the acknowledge-related clock pulse and leaves SDA high during the high period of the clock pulse. Monitoring the acknowledge bits allows for detection of unsuccessful data transfers. An unsuccessful data transfer happens if a receiving device is busy or if a system fault has occurred. In the event of an unsuccessful data transfer the bus master should reattempt communication at a later time.

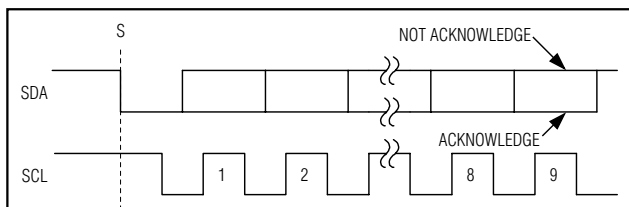

Figure 6. Acknowledge Bits

2.7V to 3.6V and 4.5V to 5.5V, Low-Power, 4-/12-Channel, 2-Wire Serial, 12-Bit ADCs

DEVICE	SLAVE ADDRESS
MAX1236/MAX1237	0110100
MAX1238/MAX1239	0110101

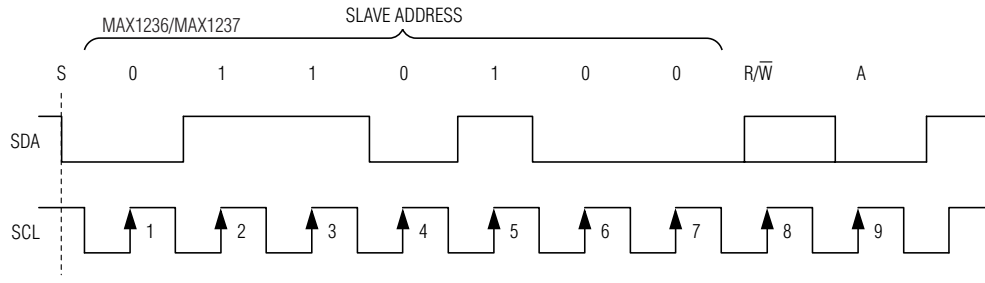

Figure 7. MAX1236/MAX1237 Slave Address Byte

Slave Address

A bus master initiates communication with a slave device by issuing a START condition followed by a slave address. When idle, the MAX1236–MAX1239 continuously wait for a START condition followed by their slave address. When the MAX1236–MAX1239 recognize their slave address, they are ready to accept or send data. The slave address has been factory programmed and is always 0110100 for the MAX1236/MAX1237, and 0110101 for MAX1238/MAX1239 (Figure 7). The least significant bit (LSB) of the address byte (R/\bar{W}) determines whether the master is writing to or reading from the MAX1236–MAX1239 ($R/\bar{W} = 0$ selects a write condition, $R/\bar{W} = 1$ selects a read condition). After receiving the address, the MAX1236–MAX1239 (slave) issues an acknowledge by pulling SDA low for one clock cycle.

Bus Timing

At power-up, the MAX1236–MAX1239 bus timing is set for fast-mode (F/S-mode) which allows conversion rates

up to 22.2ksp/s. The MAX1236–MAX1239 must operate in high-speed mode (HS-mode) to achieve conversion rates up to 94.4ksp/s. Figure 1 shows the bus timing for the MAX1236–MAX1239's 2-wire interface.

HS-Mode

At power-up, the MAX1236–MAX1239 bus timing is set for F/S-mode. The bus master selects HS-mode by addressing all devices on the bus with the HS-mode master code 0000 1XXX (X = don't care). After successfully receiving the HS-mode master code, the MAX1236–MAX1239 issue a not-acknowledge allowing SDA to be pulled high for one clock cycle (Figure 8). After the not-acknowledge, the MAX1236–MAX1239 are in HS-mode. The bus master must then send a repeated START followed by a slave address to initiate HS-mode communication. If the master generates a STOP condition the MAX1236–MAX1239 will return to F/S-mode.

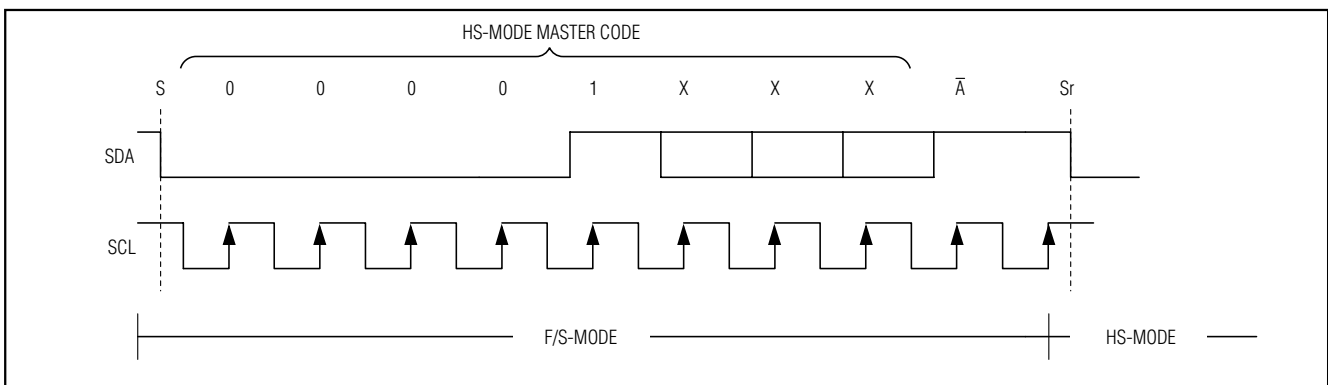

Figure 8. F/S-Mode to HS-Mode Transfer

2.7V to 3.6V and 4.5V to 5.5V, Low-Power, 4-/12-Channel, 2-Wire Serial, 12-Bit ADCs

Configuration/Setup Bytes (Write Cycle)

A write cycle begins with the bus master issuing a START condition followed by seven address bits (Figure 7) and a write bit ($R/\overline{W} = 0$). If the address byte is successfully received, the MAX1236–MAX1239 (slave) issues an acknowledge. The master then writes to the slave. The slave recognizes the received byte as the set-up byte (Table 1) if the most significant bit (MSB) is 1. If the MSB is 0, the slave recognizes that byte as the

configuration byte (Table 3). The master can write either one or two bytes to the slave in any order (setup byte then configuration byte; configuration byte then setup byte; setup byte or configuration byte only; Figure 9). If the slave receives a byte successfully, it issues an acknowledge. The master ends the write cycle by issuing a STOP condition or a repeated START condition. When operating in HS-mode, a STOP condition returns the bus into F/S-mode (see the *HS-Mode* section).

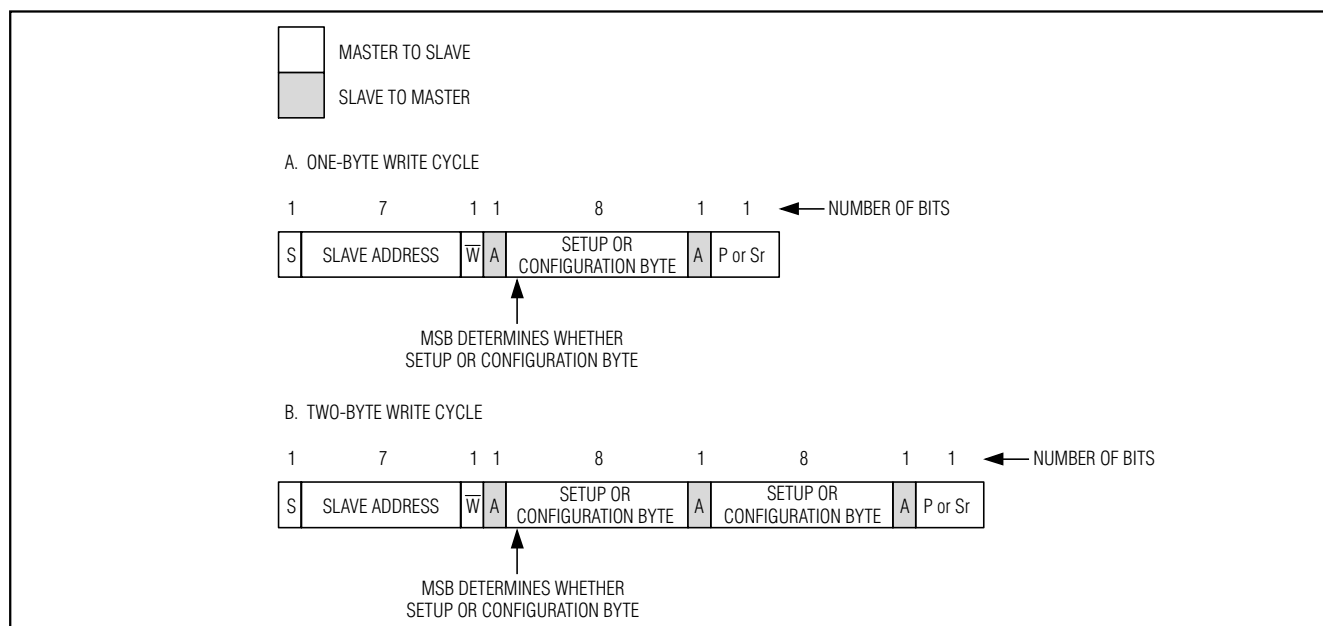

Figure 9. Write Cycle

Table 1. Setup Byte Format

BIT 7 (MSB)	BIT 6	BIT 5	BIT 4	BIT 3	BIT 2	BIT 1	BIT 0 (LSB)
REG	SEL2	SEL1	SEL0	CLK	BIP/ \overline{UNI}	RST	X
BIT	NAME	DESCRIPTION					
7	REG	Register bit. 1 = setup byte, 0 = configuration byte (see Table 2).					
6	SEL2	Three bits select the reference voltage and the state of AIN ₁ /REF (Table 6). Default to 000 at power-up.					
5	SEL1						
4	SEL0						
3	CLK	1 = external clock, 0 = internal clock. Default to 0 at power-up.					
2	BIP/ \overline{UNI}	1 = bipolar, 0 = unipolar. Default to 0 at power-up (see the <i>Unipolar/Bipolar</i> section).					
1	RST	1 = no action, 0 = resets the configuration register to default. Setup register remains unchanged.					
0	X	Don't care, can be set to 1 or 0.					

2.7V to 3.6V and 4.5V to 5.5V, Low-Power, 4-/12-Channel, 2-Wire Serial, 12-Bit ADCs

Table 2. Configuration Byte Format

BIT 7 (MSB)	BIT 6	BIT 5	BIT 4	BIT 3	BIT 2	BIT 1	BIT 0 (LSB)
REG	SCAN1	SCAN0	CS3	CS2	CS1	CS0	SGL/DIF
BIT	NAME	DESCRIPTION					
7	REG	Register bit 1 = setup byte (see Table 1), 0 = configuration byte.					
6	SCAN1	Scan select bits. Two bits select the scanning configuration (Table 5). Default to 00 at power-up.					
5	SCAN0						
4	CS3						
3	CS2	Channel select bits. Four bits select which analog input channels are to be used for conversion (Table 3 and Table 4). Default to 0000 at power-up. For MAX1236/MAX1237, CS3 and CS2 are internally set to 0.					
2	CS1						
1	CS0						
0	SGL/DIF	1 = single-ended, 0 = differential (Table 3 and Table 4). Default to 1 at power-up. See the <i>Single-Ended/Differential Input</i> section.					

Table 3. Channel Selection in Single-Ended Mode (SGL/DIF = 1)

CS3 ¹	CS2 ¹	CS1	CS0	AIN0	AIN1	AIN2	AIN3 ²	AIN4	AIN5	AIN6	AIN7	AIN8	AIN9	AIN10	AIN11 ²	GND
0	0	0	0	+												-
0	0	0	1		+											-
0	0	1	0			+										-
0	0	1	1				+									-
0	1	0	0					+								-
0	1	0	1						+							-
0	1	1	0							+						-
0	1	1	1								+					-
1	0	0	0									+				-
1	0	0	1										+			-
1	0	1	0											+		-
1	0	1	1												+	-
1	1	0	0	RESERVED												
1	1	0	1	RESERVED												
1	1	1	0	RESERVED												
1	1	1	1	RESERVED												

1. For MAX1236/MAX1237, CS3 and CS2 are internally set to 0.

2. When SEL1 = 1, a single-ended read of AIN3/REF (MAX1236/MAX1237) or AIN11/REF (MAX1238/MAX1239) will be ignored; scan will stop at AIN2 or AIN10.

2.7V to 3.6V and 4.5V to 5.5V, Low-Power, 4-/12-Channel, 2-Wire Serial, 12-Bit ADCs

Table 4. Channel Selection in Differential Mode (SGL/DIF = 0)

CS3 ¹	CS2 ¹	CS1	CS0	AIN0	AIN1	AIN2	AIN3 ²	AIN4	AIN5	AIN6	AIN7	AIN8	AIN9	AIN10	AIN11 ²
0	0	0	0	+	-										
0	0	0	1	-	+										
0	0	1	0			+	-								
0	0	1	1			-	+								
0	1	0	0					+	-						
0	1	0	1					-	+						
0	1	1	0							+	-				
0	1	1	1							-	+				
1	0	0	0									+	-		
1	0	0	1									-	+		
1	0	1	0											+	-
1	0	1	1											-	+
1	1	0	0	RESERVED											
1	1	0	1	RESERVED											
1	1	1	0	RESERVED											
1	1	1	1	RESERVED											

1. For MAX1236/MAX1237, CS3 and CS2 are internally set to 0.

2. When SEL1 = 1, a differential read between AIN2 and AIN3/REF (MAX1236/MAX1237) or AIN10 and AIN11/REF (MAX1238/MAX1239) will return the difference between GND and AIN2 or AIN10, respectively. For example, a differential read of 1011 will return the negative difference between AIN10 and GND. In differential scanning, the address increments by 2 until limit set by CS3:CS1 has been reached.

Data Byte (Read Cycle)

A read cycle must be initiated to obtain conversion results. Read cycles begin with the bus master issuing a START condition followed by seven address bits and a read bit ($R/\overline{W} = 1$). If the address byte is successfully received, the MAX1236-MAX1239 (slave) issues an acknowledge. The master then reads from the slave. The result is transmitted in two bytes; first four bits of the first byte are high, then MSB through LSB are consecutively clocked out. After the master has received the byte(s) it can issue an acknowledge if it wants to continue reading or a not-acknowledge if it no longer wishes to read. If the MAX1236-MAX1239 receive a not-acknowledge, they release SDA allowing the master to generate a STOP or a repeated START condition. See the *Clock Mode* and *Scan Mode* sections for detailed information on how data is obtained and converted.

Clock Modes

The clock mode determines the conversion clock and the data acquisition and conversion time. The clock mode also affects the scan mode. The state of the setup byte's CLK bit determines the clock mode (Table 1). At power-up the MAX1236-MAX1239 are defaulted to internal clock mode (CLK = 0).

Internal Clock

When configured for internal clock mode (CLK = 0), the MAX1236-MAX1239 use their internal oscillator as the conversion clock. In internal clock mode, the MAX1236-MAX1239 begin tracking the analog input after a valid address on the eighth rising edge of the clock. On the falling edge of the ninth clock, the analog signal is acquired and the conversion begins. While converting the analog input signal, the MAX1236-MAX1239 holds SCL low (clock stretching). After the conversion completes, the results are stored in internal memory. If the scan mode is set for multiple conversions, they will all happen in succession with each additional result stored in memory. The MAX1236/MAX1237 contain four 12-bit blocks of memory, and the MAX1238/MAX1239 contain twelve 12-bit blocks of memory. Once all conversions are complete, the MAX1236-MAX1239 release SCL allowing it to be pulled high. The master may now clock the results out of the memory in the same order the scan conversion has been done at a clock rate of up to 1.7MHz. SCL will be stretched for a maximum of 0.3µs per channel, see Figure 10.

The device memory contains all of the conversion results when the MAX1236-MAX1239 release SCL. The converted results are read back in a first-in-first-out

2.7V to 3.6V and 4.5V to 5.5V, Low-Power, 4-/12-Channel, 2-Wire Serial, 12-Bit ADCs

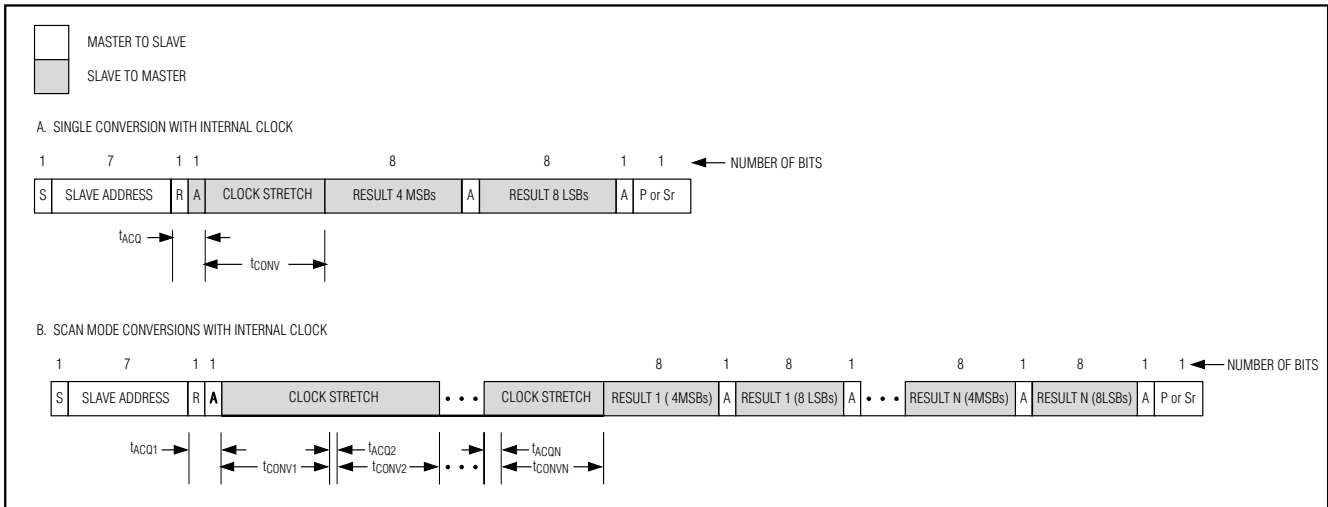

Figure 10. Internal Clock Mode Read Cycles

(FIFO) sequence. If AIN_/REF is set to be a reference input or output (SEL1 = 1, Table 6), AIN_/REF will be excluded from a multichannel scan. The memory contents can be read continuously. If reading continues past the result stored in memory, the pointer will wrap around and point to the first result. Note that only the current conversion results will be read from memory. The device must be addressed with a read command to obtain new conversion results.

The internal clock mode's clock stretching quiets the SCL bus signal reducing the system noise during conversion. Using the internal clock also frees the bus master (typically a microcontroller) from the burden of running the conversion clock, allowing it to perform other tasks that do not need to use the bus.

External Clock

When configured for external clock mode (CLK = 1), the MAX1236-MAX1239 use the SCL as the conversion

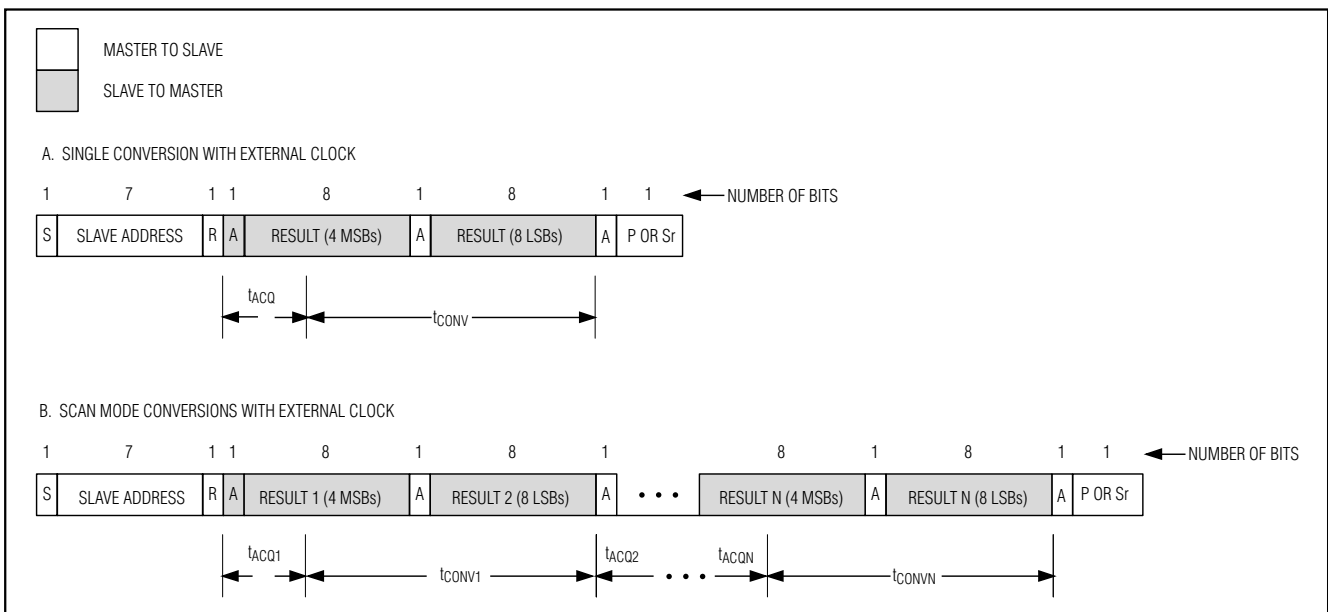

Figure 11. External Clock Mode Read Cycle

2.7V to 3.6V and 4.5V to 5.5V, Low-Power, 4-/12-Channel, 2-Wire Serial, 12-Bit ADCs

Table 5. Scanning Configuration

SCAN1	SCAN0	SCANNING CONFIGURATION
0	0	Scans up from AIN0 to the input selected by CS3–CS0. When CS3–CS0 exceeds 11, the scanning will stop at AIN11. When AIN_/REF is set to be a REF in/out, scanning will stop at AIN10 or AIN3.
0	1	*Converts the input selected by CS3–CS0 eight times (see Tables 3 and 4).
1	0	Scans up from AIN2 to the input selected by CS1 and CS0. When CS1 and CS0 are set for AIN0–AIN2 the scanning will stop at AIN2 (MAX1236/MAX1237). When AIN_/REF is set to be a REF IN/OUT, scanning will stop at AIN3 or AIN10.
		Scans up from AIN6 to the input selected by CS3–CS0. When CS3–CS0 is set for AIN0–AIN6 scanning will stop at AIN6 (MAX1238/MAX1239). When AIN_/REF is set to be a REF IN/OUT, scanning will stop at AIN or AIN10.
1	1	*Converts channel selected by CS3–CS0.

*When operating in external clock mode there is no difference between $SCAN[1:0] = 01$ and $SCAN[1:0] = 11$ and converting will occur perpetually until not-acknowledge occurs.

clock. In external clock mode, the MAX1236–MAX1239 begin tracking the analog input on the ninth rising clock edge of a valid slave address byte. Two SCL clock cycles later the analog signal is acquired and the conversion begins. Unlike internal clock mode, converted data is available immediately after the first four empty high bits. The device will continuously convert input channels dictated by the scan mode until given a not acknowledge. There is no need to re-address the device with a read command to obtain new conversion results (see Figure 11).

The conversion must complete in 1ms or droop on the track-and-hold capacitor, will degrade conversion results. Use internal clock mode if the SCL clock period exceeds 60μs.

The MAX1236–MAX1239 must operate in external clock mode for conversion rates from 40ksps to 94.4ksps. Below 40ksps internal clock mode is recommended due to much smaller power consumption.

Scan Mode

SCAN0 and SCAN1 of the configuration byte set the scan mode configuration. Table 5 shows the scanning configurations. If AIN_/REF is set to be a reference input or output ($SEL1 = 1$, Table 6), AIN_/REF will be excluded from a multichannel scan. The scanned results are written to memory in the same order as the conversion. Read the results from memory in the order they were converted. Each result needs a 2-byte transmission, the first byte begins with four empty bits during which SDA is left high. Each byte has to be acknowledged by the master or the memory transmission will be terminated. It is not possible to read the memory independently of conversion.

Applications Information

Power-On Reset

When power is first applied, the MAX1236–MAX1239 are in power-down mode (see the *Automatic Power-Down Mode* section). The configuration and setup registers (Table 1 and Table 2) will default to a single-ended, unipolar, single channel conversion on AIN0 using the internal clock with V_{DD} as the reference and AIN_/REF configured as an analog input. The memory contents are unknown after power-up.

Automatic Shutdown

$SEL[2:0]$ of the setup byte (Table 1 and Table 6) control the state of the reference and AIN_/REF. If automatic shutdown is selected ($SEL[2:0] = 100$), shutdown will occur between conversions when the MAX1236–MAX1239 are idle. When operating in external clock mode, a STOP, not-acknowledge or repeated START, condition must be issued to place the devices in idle mode and benefit from automatic shutdown. A STOP condition is not necessary in internal clock mode to benefit from automatic shutdown because power-down occurs once all contents are written to memory (Figure 10). All analog circuitry is inactive in shutdown and supply current is less than 0.5μA. The digital conversion results are maintained in memory during shutdown and are available for access through the serial interface at any time prior to a STOP or a repeated START condition.

When idle the MAX1236–MAX1239 continuously wait for a START condition followed by their slave address (see the *Slave Address* section). Upon reading a valid address byte the MAX1236–MAX1239 power-up. The internal reference requires 10ms to wake up, so when using the internal reference it should be powered up 10ms prior to conversion or powered continuously.

2.7V to 3.6V and 4.5V to 5.5V, Low-Power, 4-/12-Channel, 2-Wire Serial, 12-Bit ADCs

Table 6. Reference Voltage and AIN_/REF Format

SEL2	SEL1	SEL0	REFERENCE VOLTAGE	AIN_/REF	INTERNAL REFERENCE STATE
0	0	X	V _{DD}	Analog Input	Always Off
0	1	X	External Reference	Reference Input	Always Off
1	0	0	Internal Reference	Analog Input	Always Off
1	0	1	Internal Reference	Analog Input	Always On
1	1	0	Internal Reference	Reference Output	Always Off
1	1	1	Internal Reference	Reference Output	Always On

Wake-up is invisible when using an external reference or V_{DD} as the reference. On initial power-up the MAX1236-MAX1239 default to shutdown mode.

Automatic shutdown results in dramatic power savings, particularly at slow conversion rates and with internal clock. For example, at a conversion rate of 10ksps, the average supply current for the MAX1237 is 60μA (typ) and drops to 6μA (typ) at 1ksps. At 0.1ksps the average supply current is just 1μA, or a minuscule 3μW of power consumption, see Average Supply Current vs. Conversion Rate in the *Typical Operating Characteristics* section).

Reference Voltage

SEL[2:0] of the setup byte (Table 1) control the reference and the AIN_/REF configuration (Table 6). When AIN_/REF is configured to be a reference input or reference output (SEL1 = 1), differential conversions on AIN_/REF appear as if AIN_/REF is connected to GND (see Note 2 and Table 4). Single-ended conversion in scan mode AIN_/REF will be ignored by internal limiter, which sets the highest available channel at AIN2 or AIN10.

Internal Reference

The internal reference is 4.096V for the MAX1236/MAX1238 and 2.048V for the MAX1237/MAX1239. SEL1 of the setup byte controls whether AIN_/REF is used for an analog input or a reference (Table 6). When AIN_/REF is configured to be an internal reference output (SEL[2:1] = 11), decouple AIN_/REF to GND with a 0.1μF capacitor. Once powered up, the reference always remains on until reconfigured. The reference should not be used to supply current for external circuitry.

External Reference

The external reference can range from 1V to V_{DD}. For maximum conversion accuracy, the reference must be able to deliver up to 40μA and have an output impedance of 500kΩ or less. If the reference has a higher output impedance or is noisy, bypass it to GND as close to AIN_/REF as possible with a 0.1μF capacitor.

Transfer Functions

Output data coding for the MAX1236-MAX1239 is binary in unipolar mode and two's complement in bipolar mode with 1LSB = (V_{REF}/2N) where "N" is the number of bits (12). Code transitions occur halfway between successive-integer LSB values. Figure 12 and Figure 13 show the input/output (I/O) transfer functions for unipolar and bipolar operations, respectively.

Layout, Grounding, and Bypassing

Only use PC boards. Wire-wrap configurations are not recommended since the layout should ensure proper separation of analog and digital traces. Do not run analog and digital lines parallel to each other, and do not layout digital signal paths underneath the ADC package. Use separate analog and digital PC board ground sections with only one star point (Figure 14) connecting the two ground systems (analog and digital). For lowest noise operation, ensure the ground return to the star

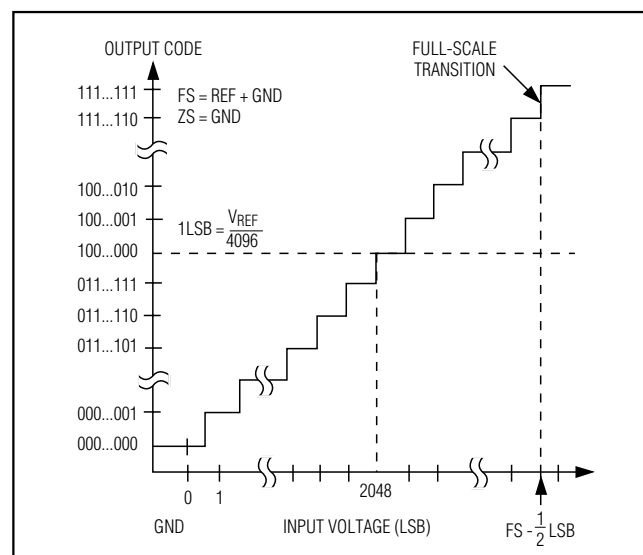

Figure 12. Unipolar Transfer Function

2.7V to 3.6V and 4.5V to 5.5V, Low-Power, 4-/12-Channel, 2-Wire Serial, 12-Bit ADCs

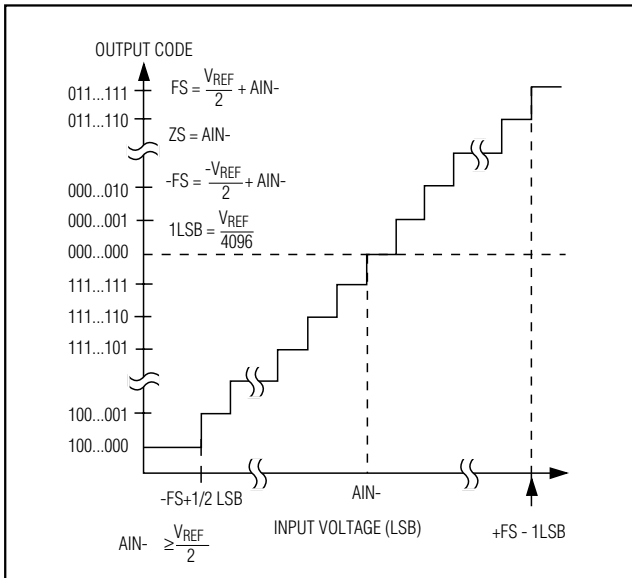

Figure 13. Bipolar Transfer Function

ground's power supply is low impedance and as short as possible. Route digital signals far away from sensitive analog and reference inputs.

High-frequency noise in the power supply (V_{DD}) could influence the proper operation of the ADC's fast comparator. Bypass V_{DD} to the star ground with a network of two parallel capacitors, 0.1 μ F and 4.7 μ F, located as close as possible to the MAX1236-MAX1239 power-supply pin. Minimize capacitor lead length for best supply noise rejection, and add an attenuation resistor (5 Ω) in series with the power supply, if it is extremely noisy.

Definitions

Integral Nonlinearity

Integral nonlinearity (INL) is the deviation of the values on an actual transfer function from a straight line. This straight line can be either a best straight-line fit or a line drawn between the endpoints of the transfer function, once offset and gain errors have been nullified. The MAX1236-MAX1239's INL is measured using the endpoint.

Differential Nonlinearity

Differential nonlinearity (DNL) is the difference between an actual step width and the ideal value of 1LSB. A DNL error specification of less than 1LSB guarantees no missing codes and a monotonic transfer function.

Aperture Jitter

Aperture jitter (t_{AJ}) is the sample-to-sample variation in the time between the samples.

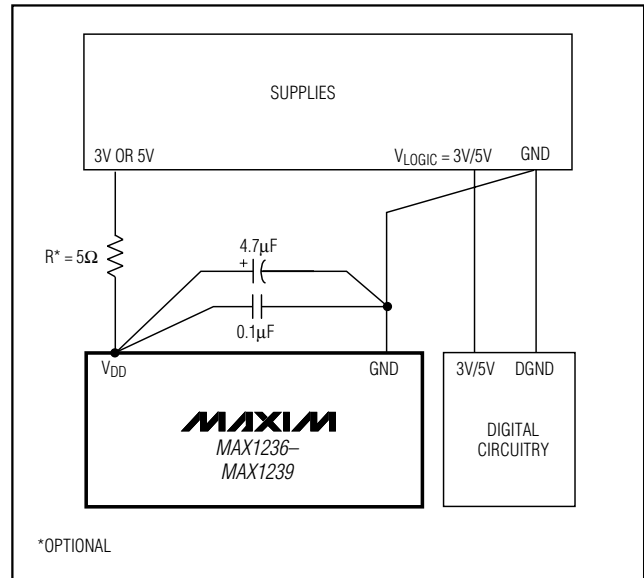

Figure 14. Power-Supply Grounding Connection

Aperture Delay

Aperture delay (t_{AD}) is the time between the falling edge of the sampling clock and the instant when an actual sample is taken.

Signal-to-Noise Ratio

For a waveform perfectly reconstructed from digital samples, the theoretical maximum SNR is the ratio of the full-scale analog input (RMS value) to the rms quantization error (residual error). The ideal, theoretical minimum analog-to-digital noise is caused by quantization error only and results directly from the ADC's resolution (N Bits):

$$SNR_{MAX}[dB] = 6.02dB \times N + 1.76dB$$

In reality, there are other noise sources besides quantization noise: thermal noise, reference noise, clock jitter, etc. SNR is computed by taking the ratio of the RMS signal to the RMS noise, which includes all spectral components minus the fundamental, the first five harmonics, and the DC offset.

Signal-to-Noise Plus Distortion

Signal-to-noise plus distortion (SINAD) is the ratio of the fundamental input frequency's RMS amplitude to RMS equivalent of all other ADC output signals.

$$SINAD(dB) = 20 \times \log \left[\frac{\text{Signal}_{RMS}}{\text{Noise}_{RMS} + \text{THDRMS}} \right]$$

2.7V to 3.6V and 4.5V to 5.5V, Low-Power, 4-/12-Channel, 2-Wire Serial, 12-Bit ADCs

Effective Number of Bits

Effective number of bits (ENOB) indicates the global accuracy of an ADC at a specific input frequency and sampling rate. An ideal ADC's error consists of quantization noise only. With an input range equal to the ADC's full-scale range, calculate the ENOB as follows:

$$ENOB = (SINAD - 1.76)/6.02$$

Total Harmonic Distortion

Total harmonic distortion (THD) is the ratio of the RMS sum of the input signal's first five harmonics to the fundamental itself. This is expressed as:

$$THD = 20 \times \log \left(\sqrt{\frac{V_2^2 + V_3^2 + V_4^2 + V_5^2}{V_1^2}} \right)$$

where V_1 is the fundamental amplitude, and V_2 through V_5 are the amplitudes of the 2nd through 5th order harmonics.

Spurious-Free Dynamic Range

Spurious-free dynamic range (SFDR) is the ratio of RMS amplitude of the fundamental (maximum signal component) to the RMS value of the next largest distortion component.

Chip Information

MAX1236/MAX1237 TRANSISTORS COUNT: 11,362

MAX1238/MAX1239 TRANSISTORS COUNT: 12,956

PROCESS: BiCMOS

Selector Guide

PART	INPUT CHANNELS	INTERNAL REFERENCE (V)	SUPPLY VOLTAGE (V)
MAX1236EUA	4	4.096	4.5 to 5.5
MAX1237EUA	4	2.048	2.7 to 3.6
MAX1238EEE	12	4.096	4.5 to 5.5
MAX1239EEE	12	2.048	2.7 to 3.6

*Future product—contact factory for availability.

Typical Operating Circuit

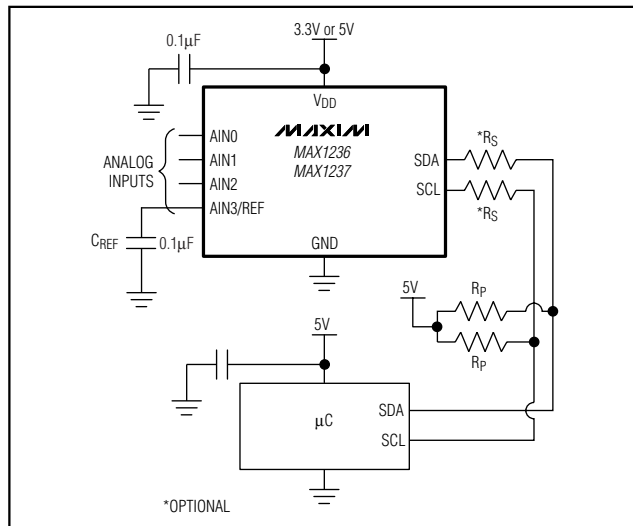

Pin Configurations

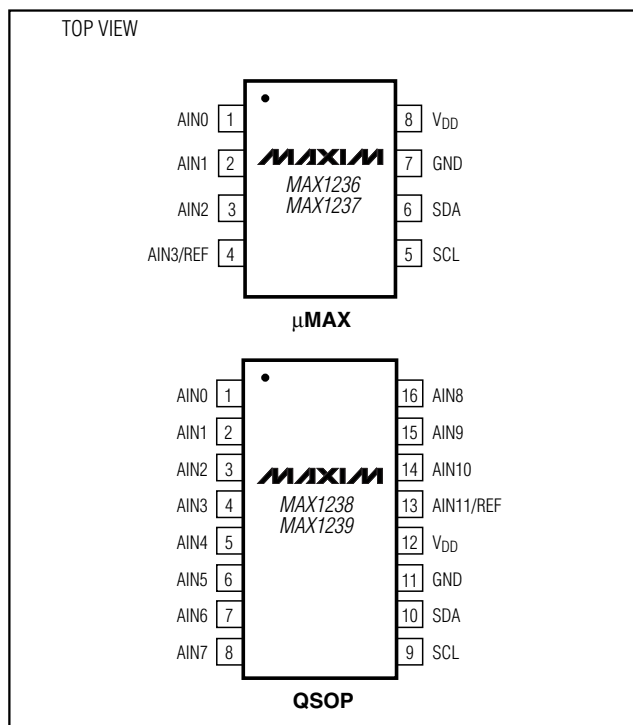

2.7V to 3.6V and 4.5V to 5.5V, Low-Power, 4-/12-Channel, 2-Wire Serial, 12-Bit ADCs

Package Information

MAX1236-MAX1239

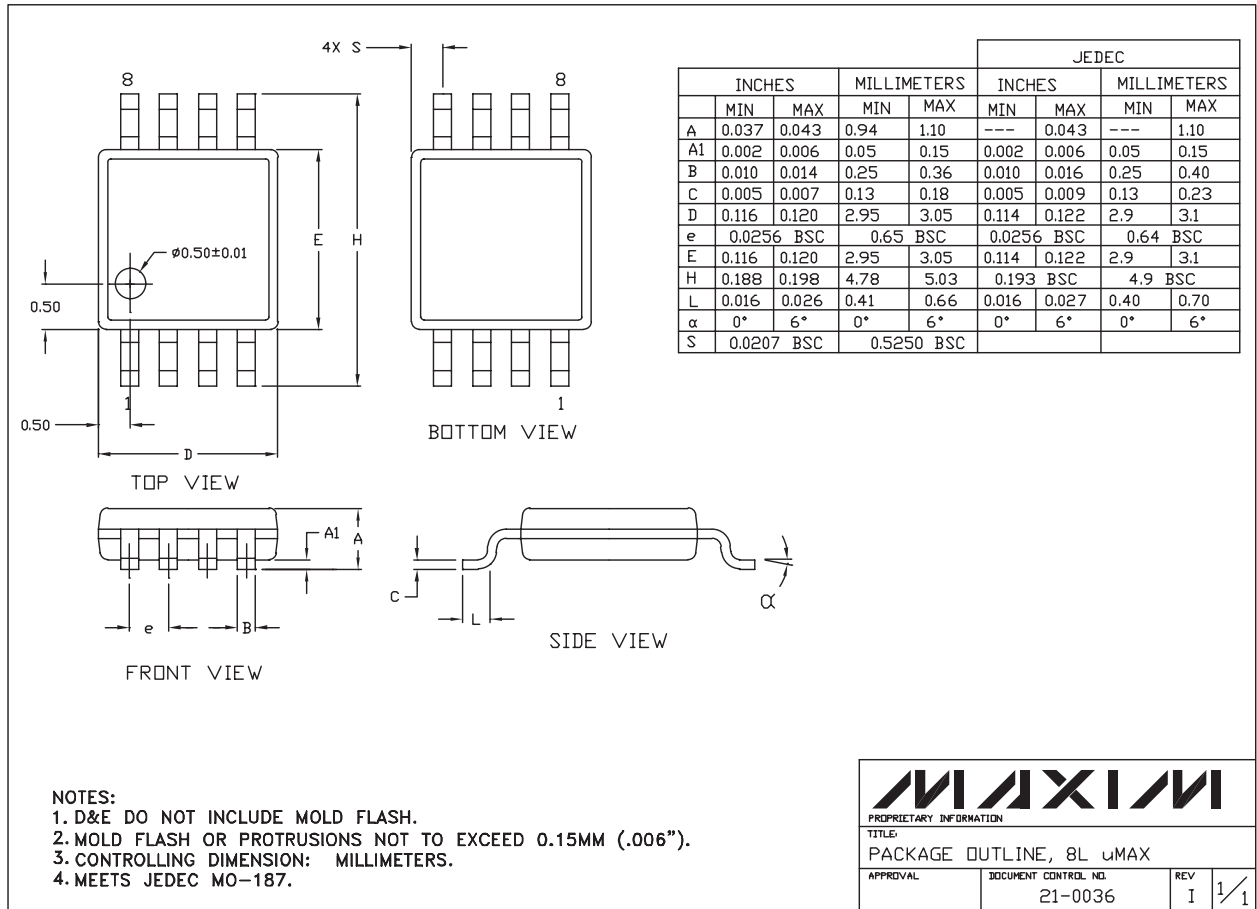

8LUMAXD.EPS

2.7V to 3.6V and 4.5V to 5.5V, Low-Power, 4-/12-Channel, 2-Wire Serial, 12-Bit ADCs

Package Information (continued)

DIM	INCHES		MILLIMETERS	
	MIN	MAX	MIN	MAX
A	.061	.068	1.55	1.73
A1	.004	.0098	0.102	0.249
A2	.055	.061	1.40	1.55
B	.008	.012	0.20	0.31
C	.0075	.0098	0.191	0.249
D	SEE VARIATIONS			
E	.150	.157	3.81	3.99
e	.025 BSC		0.635 BSC	
H	.230	.244	5.84	6.20
h	.010	.016	0.25	0.41
L	.016	.035	0.41	0.89
N	SEE VARIATIONS			
α	0°	8°	0°	8°

VARIATIONS:

DIM	INCHES		MILLIMETERS		N
	MIN.	MAX.	MIN.	MAX.	
D	.189	.196	4.80	4.98	16 AA
S	.0020	.0070	0.05	0.18	
D	.337	.344	8.56	8.74	20 AB
S	.0500	.0550	1.270	1.397	
D	.337	.344	8.56	8.74	24 AC
S	.0250	.0300	0.635	0.762	
D	.386	.393	9.80	9.98	28 AD
S	.0250	.0300	0.635	0.762	

NOTES:

- 1). D & E DO NOT INCLUDE MOLD FLASH OR PROTRUSIONS.
- 2). MOLD FLASH OR PROTRUSIONS NOT TO EXCEED .006" PER SIDE.
- 3). CONTROLLING DIMENSIONS: INCHES.
- 4). MEETS JEDEC MO137.

MAXIM

PROPRIETARY INFORMATION

TITLE:
PACKAGE OUTLINE, QSDP, .150", .025" LEAD PITCH

APPROVAL	DOCUMENT CONTROL NO.	REV	1/1
	21-0055	D	

QSDPERS

Maxim cannot assume responsibility for use of any circuitry other than circuitry entirely embodied in a Maxim product. No circuit patent licenses are implied. Maxim reserves the right to change the circuitry and specifications without notice at any time.

22 _____ **Maxim Integrated Products, 120 San Gabriel Drive, Sunnyvale, CA 94086 408-737-7600**